

Ceiling diffusers

Type DLQ

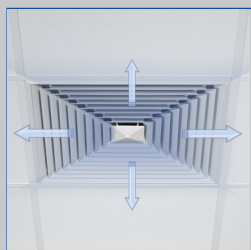

Horizontal air discharge



With plenum box

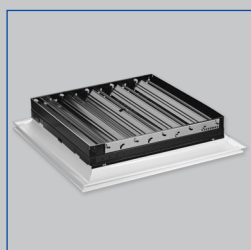

With damper blade

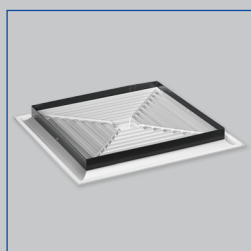

With connecting frame

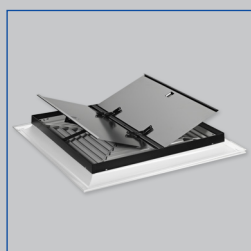

With butterfly damper

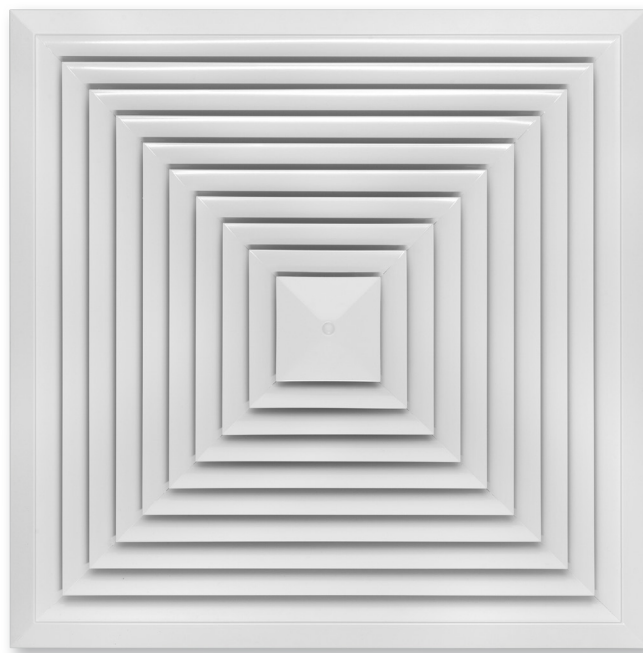

For four-way horizontal supply air discharge, with fixed air control blades – sheet steel diffuser face

Square ceiling diffusers

- Nominal sizes 250, 300, 400, 500, 600, 625
- Volume flow rate range 20 – 700 l/s or 72 – 2520 m³/h
- Square diffuser face
- Diffuser face made of sheet steel, powder-coated
- For supply and extract air
- For variable and constant volume flows
- For all types of ceiling systems
- High induction results in a rapid reduction of the temperature difference and airflow velocity

Optional equipment and accessories

- Exposed diffuser face available in RAL CLASSIC colours
- Horizontal or vertical duct connection
- Blanking plates for adjusting the discharge direction
- Duct cross bar for installation without plenum box
- Plenum box with cord-operated damper blade and pressure tap

Type		Page
DLQ	General information	DLQ – 2
	Function	DLQ – 3
	Technical data	DLQ – 4
	Quick sizing	DLQ – 5
	Specification text	DLQ – 7
	Order code	DLQ – 8
	Variants	DLQ – 9
	Dimensions and weight	DLQ – 11
	Product details	DLQ – 14
	Installation examples	DLQ – 15
	Installation details	DLQ – 16
	Commissioning	DLQ – 18
	Basic information and nomenclature	DLQ – 20

Application

Application

- Type DLQ ceiling diffusers are used as supply air or extract air diffusers for comfort zones
- Attractive design element for building owners and architects with demanding aesthetic requirements
- Horizontal four-way supply air discharge for mixed flow ventilation
- High induction results in a rapid reduction of the temperature difference and airflow velocity (supply air variant)
- For variable and constant volume flows
- For supply air to room air temperature

- differences from –10 to +10 K
- For room heights up to 4 m (lower edge of suspended ceiling)
- For all types of ceiling systems

Special characteristics

- Horizontal four-way supply air discharge
- Diffuser face made of galvanised sheet steel
- For all types of ceiling systems
- Horizontal or vertical duct connection

Nominal sizes

- 250, 300, 400, 500, 600, 625

Description

Variant

- Square diffuser face

Connection

- A: Diffuser face only
- AR: Vertical duct connection, with connecting frame
- AG: Vertical duct connection, with blades
- C: Vertical duct connection with butterfly damper
- AK: Horizontal duct connection, with plenum box

Parts and characteristics

- Square diffuser face with fixed air control blades
- Diffuser front frame
- Simple installation of the diffuser face due to central fixing screw with decorative cap

Accessories

- Lip seal

Construction features

- Spigot suitable for circular ducts to EN 1506 or EN 13180

Materials and surfaces

- Diffuser face, connecting frame and butterfly damper made of sheet steel
- AK: Plenum box and cross bar made of galvanised sheet steel
- X: Plenum box made of plastic and galvanised sheet steel
- Lip seal made of rubber
- Attachments are dip coated RAL 9005, jet black
- Diffuser face powder-coated RAL 9010, pure white
- P1: Powder-coated, RAL CLASSIC colour

Standards and guidelines

- Sound power level of the air-regenerated noise measured according to EN ISO 5135

Maintenance

- Maintenance-free as construction and materials are not subject to wear
- Inspection and cleaning to VDI 6022

Functional description

Ceiling diffusers direct the air from air conditioning systems into the room. The resulting airflow induces high levels of room air, thereby rapidly reducing the airflow velocity and the temperature difference between supply air and room air. Ceiling diffusers allow for large volume flow rates. The result is a mixed flow ventilation in comfort zones, with good overall room ventilation, creating

only very little turbulence in the occupied zone. Type DLQ ceiling diffusers have fixed blades. Horizontal air discharge is four-way. The supply air to room air temperature difference may range from -10 to $+10$ K.

To give rooms an aesthetic, uniform look, Type DLQ diffusers may also be used for extract air.

Schematic illustration of the DLQ, with plenum box for horizontal duct connection

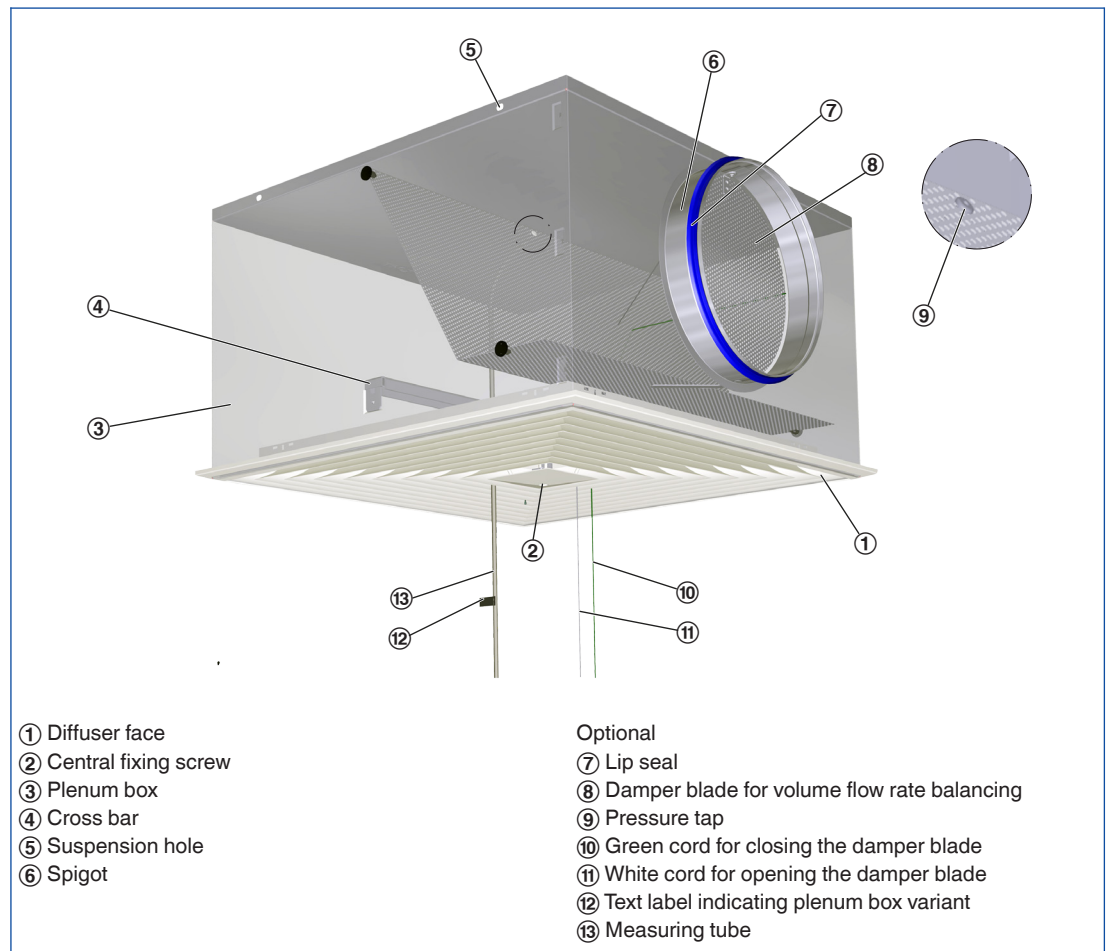

Air patterns

Horizontal air discharge

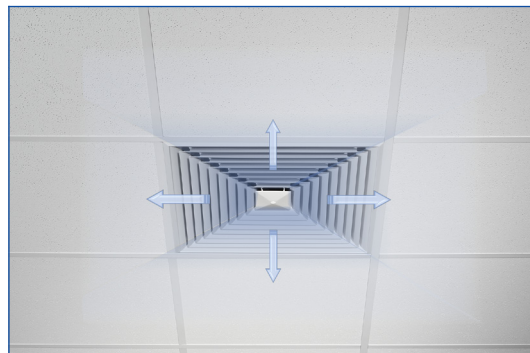

Nominal sizes	250, 300, 400, 500, 600, 625 mm
Minimum volume flow rate	20 – 250 l/s or 72 – 900 m ³ /h
Maximum volume flow rate, with $L_{WA} \cong 50$ dB(A)	575 – 700 l/s or 2070 – 2520 m ³ /h
Supply air to room air temperature difference	-10 to +10 K

Quick sizing tables provide a good overview of the volume flow rates and corresponding sound power levels and differential pressures. The maximum volume flow rates apply to a sound power level of approx. 50 dB (A). Exact values for all parameters can be determined with our Easy Product Finder design programme.

DLQ-A, DLQ-AR (supply air), sound power level and total differential pressure

Nominal size	\dot{V}		Δp_t	L_{WA}
	l/s	m ³ /h	Pa	dB(A)
250	20	72	3	<15
	55	198	20	26
	95	342	59	40
	130	468	111	50
300	35	126	2	<15
	95	342	18	24
	155	558	47	38
	210	756	87	50
400	75	270	2	<15
	190	684	13	25
	310	1116	35	38
	430	1548	68	50
500	135	486	2	<15
	295	1062	10	27
	455	1638	23	39
	615	2214	43	50
600	220	792	2	15
	380	1440	8	34
	535	1980	15	43
	690	2484	24	50
625	250	900	2	20
	400	1440	6	34
	550	1980	12	43
	700	2520	19	50

DLQ-AK (supply air), sound power level and total differential pressure

Nominal size	\dot{V} l/s	\dot{V} m ³ /h	Damper blade position					
			0°		45°		90°	
			Δp_t	L_{WA}	Δp_t	L_{WA}	Δp_t	L_{WA}
			Pa	dB(A)	Pa	dB(A)	Pa	dB(A)
250	20	72	5	<15	5	<15	10	<15
	35	126	14	22	16	22	31	25
	60	216	41	38	46	38	92	41
	90	324	92	51	104	51	208	53
300	35	126	6	9	9	11	20	19
	70	252	26	30	37	32	81	39
	100	360	53	41	75	43	165	49
	135	486	96	51	137	54	301	59
400	75	270	9	13	15	21	33	30
	130	468	28	31	46	39	98	45
	185	666	56	42	93	50	198	57
	235	846	90	50	150	61	319	67
500	135	486	12	16	15	19	48	35
	210	756	28	32	36	35	116	49
	285	1026	52	42	66	45	213	58
	360	1296	83	50	105	53	340	65
600	220	792	12	18	19	26	49	35
	330	1188	26	32	44	39	111	47
	440	1584	46	42	78	49	197	57
	545	1962	71	50	119	58	303	66
625	250	900	14	21	26	33	64	39
	330	1188	24	31	46	42	111	47
	410	1476	37	39	70	49	171	55
	575	2070	74	50	138	61	336	74

Sizing example

Given data

$\dot{V} = 300$ l/s (1280 m³/h)
 Square ceiling diffuser, steel, with fixed air control blades
 Maximum sound power level 40 dB(A) with damper blade position 45°
 Four-way air discharge

Quick sizing

Type DLQ
 Nominal sizes: 600, 625
 Selected: DLQ/600

This specification text describes the general properties of the product. Texts for variants can be generated with our Easy Product Finder design programme.

Ceiling diffusers with square diffuser face. Supply air and extract air variants for comfort zones. Diffuser face with fixed air control blades for horizontal four-way air discharge. For installation into all types of suspended ceilings. Ready-to-install component which consists of the galvanised sheet steel diffuser face with fixed air control blades, a diffuser front frame with perimeter seal and connecting frame, opposed action blades, butterfly damper or a plenum box. Diffuser face suitable for central screw fixing. Sound power level of the air-regenerated noise measured according to EN ISO 5135.

Special characteristics

- Horizontal four-way supply air discharge
- Diffuser face made of galvanised sheet steel
- For all types of ceiling systems
- Horizontal or vertical duct connection

Materials and surfaces

- Diffuser face, connecting frame and butterfly damper made of sheet steel
- AK: Plenum box and cross bar made of galvanised sheet steel
- X: Plenum box made of plastic and galvanised sheet steel

- Lip seal made of rubber
- Attachments are dip coated RAL 9005, jet black
- Diffuser face powder-coated RAL 9010, pure white
- P1: Powder-coated, RAL CLASSIC colour

Technical data

- Nominal sizes: 250, 300, 400, 500, 600, 625 mm
- Minimum volume flow rate: 20 – 250 l/s or 72 – 900 m³/h
- Maximum volume flow rate, with $L_{WA} \cong 50$ dB(A): 575 – 700 l/s or 2070 – 2520 m³/h
- Supply air to room air temperature difference: -10 to +10 K

Sizing data

- \dot{V} _____
[m³/h]

- Δp_i _____
[Pa]

Air-regenerated noise

- L_{WA} _____
[dB(A)]

DLQ

DLQ – ZH – M – L / 500 / P1 – RAL ...					
1	2	3	4	5	6

1 Type

DLQ Ceiling diffuser

2 Connection

- A** Diffuser face only
- AR** Vertical, with connecting frame
- AG** Vertical, with blades (not for nominal size 250)
- C** Vertical, with butterfly damper
- ZH** Horizontal, supply air, with plenum box
- AH** Horizontal, extract air, with plenum box

3 Damper blade for volume flow rate balancing

- No entry: without damper blade
Only for connections ZH, AH
- M** With damper blade
- MN** With cords and pressure tap

4 Accessories

- No entry: without accessories
- L** With lip seal (only with plenum box)

5 Nominal size [mm]

- 250**
- 300**
- 400**
- 500**
- 600**
- 625**

6 Exposed surface

- No entry: powder-coated RAL 9010, pure white
 - P1** Powder-coated, specify RAL CLASSIC colour
- Gloss level
- RAL 9010 50 %
 - RAL 9006 30 %
 - All other RAL colours 70 %

Order example: DLQ-AK-M-L/500

Connection	Horizontal, with plenum box
Damper blade for volume flow rate balancing	With damper blade
Accessories	With lip seal
Nominal size	500
Exposed surface	RAL 9010, pure white, gloss level 50 %

DLQ/250

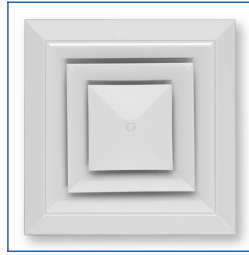

DLQ/300

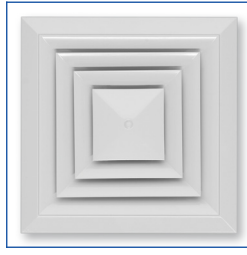

DLQ/400

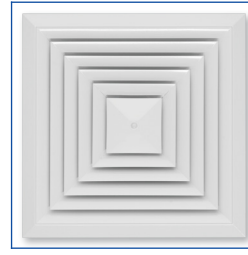

DLQ/500

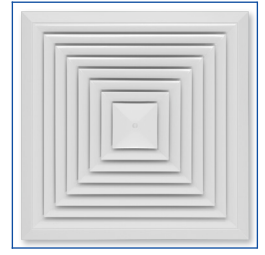

DLQ/600

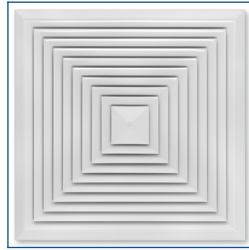

DLQ/625

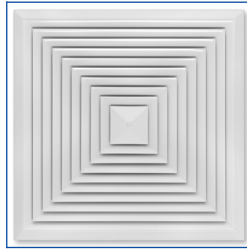

DLQ-A

Variant

- Ceiling diffuser with square diffuser face

Nominal sizes

- 250, 300, 400, 500, 600, 625

Parts and characteristics

- Square diffuser face
- Simple installation of the diffuser face due to central fixing screw with decorative cap

DLQ-AR

Variant

- Ceiling diffuser with square diffuser face
- With connecting frame

Nominal sizes

- 250, 300, 400, 500, 600, 625

Parts and characteristics

- Square diffuser face
- Connecting frame for installation of the diffuser into vertical ducts
- Simple installation of the diffuser face due to central fixing screw with decorative cap

DLQ-C

Variant

- Ceiling diffuser with square diffuser face
- With connecting frame
- With butterfly damper

Nominal sizes

- 250, 300, 400, 500, 600, 625

Parts and characteristics

- Square diffuser face
- Connecting frame for installation of the diffuser into vertical ducts
- Butterfly damper for volume flow rate balancing
- Simple installation of the diffuser face due to central fixing screw with decorative cap

DLQ-AG

Variant

- Ceiling diffuser with square diffuser face
- With connecting frame
- With opposed action blades

Nominal sizes

- 250, 300, 400, 500, 600, 625

Parts and characteristics

- Square diffuser face with fixed air control blades
- Connecting frame for installation of the diffuser into vertical ducts
- Damper blade for volume flow rate balancing
- Simple installation of the diffuser face due to central fixing screw with decorative cap

DLQ-AK

Variant

- Ceiling diffuser with square diffuser face
- With plenum box for horizontal duct connection

Nominal sizes

- 250, 300, 400, 500, 600, 625

Parts and characteristics

- Square diffuser face
- Plenum box for horizontal duct connection
- Square opening to accommodate the diffuser face
- Equalising element that ensures a uniform

airflow through the diffuser face (supply air variant)

- Simple installation of the diffuser face due to central fixing screw with decorative cap
- Damper blade for volume flow rate balancing (optional)
- Pressure tap and cord-operated damper blade for volume flow rate balancing (optional)
- Lip seal (optional)

Construction features

- Spigot suitable for circular ducts to EN 1506 or EN 13180

DLQ-A

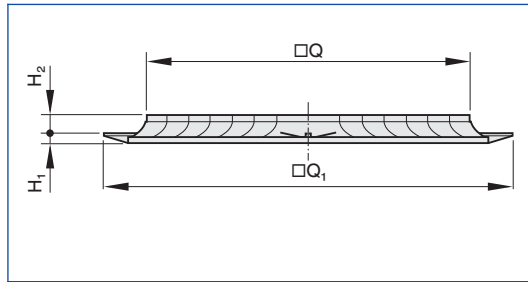

DLQ-A

Nominal size	$\square Q$ mm	$\square Q_1$ mm	H_1 mm	H_2 mm	m kg
250	140	248	13	29	0.8
300	190	298	13	29	1.1
400	290	398	13	29	1.9
500	390	498	13	29	2.8
600	490	598	13	29	4.0
625	515	623	13	29	4.2

DLQ-AR

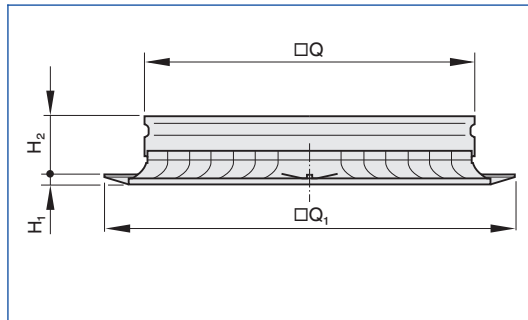

DLQ-AR

Nominal size	$\square Q$ mm	$\square Q_1$ mm	H_1 mm	H_2 mm	m kg
250	143	248	13	52	1.0
300	193	298	13	52	1.4
400	293	398	13	52	2.3
500	393	498	13	52	3.3
600	493	598	13	52	4.6
625	518	623	13	52	4.8

DLQ-C

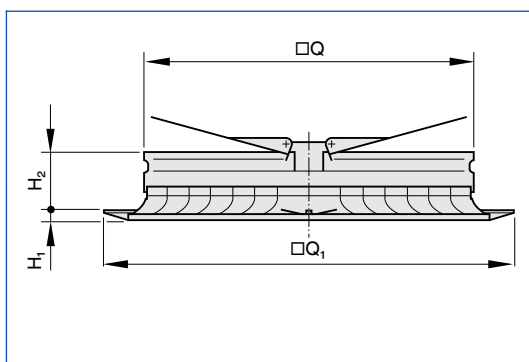

DLQ-C

Nominal size	$\square Q$	$\square Q_1$	H_1	H_2	m kg
	mm	mm	mm	mm	
250	143	248	13	52	1.5
300	193	298	13	52	2.1
400	293	398	13	52	3.5
500	393	498	13	52	5.2
600	493	598	13	52	7.4
625	518	623	13	52	7.9

DLQ-AG

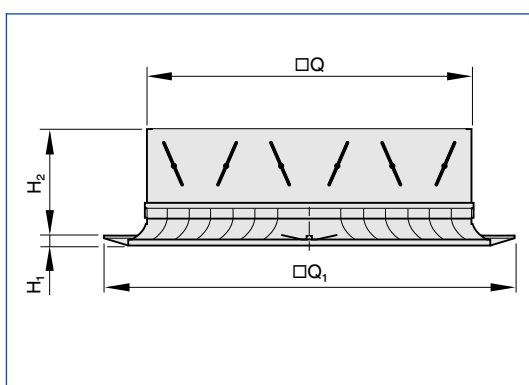

DLQ-AG

Nominal size	$\square Q$	$\square Q_1$	H_1	H_2	m kg
	mm	mm	mm	mm	
250	143	248	13	95	1.3
300	193	298	13	95	1.8
400	293	398	13	95	3.1
500	393	498	13	95	4.6
600	493	598	13	95	6.5
625	518	623	13	95	7.2

Square diffuser face with plenum box for horizontal duct connection

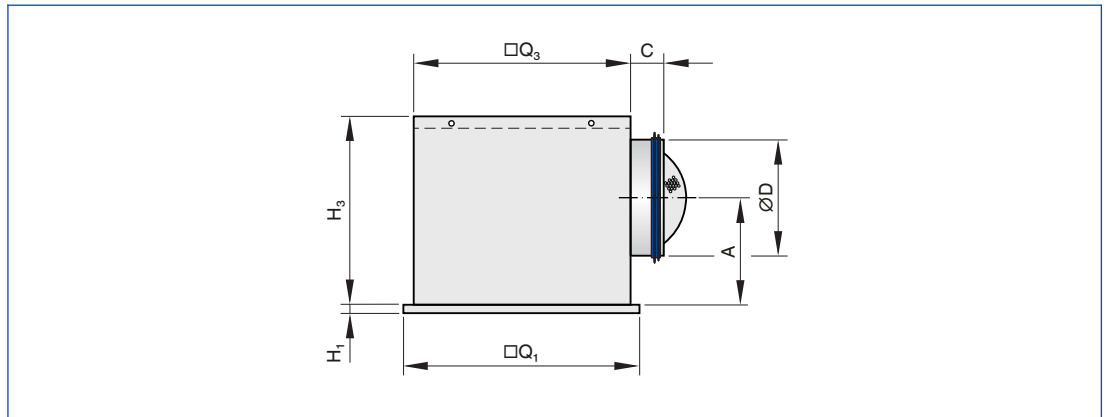

DLQ-AK

Nominal size	□Q ₁	H ₁	□Q ₃	H ₃	ØD	A	C	Plenum box	m
	mm	mm	mm	mm	mm	mm	mm		kg
250	248	13	216	250	158	139	50	AK-Uni-008	3.0
300	298	13	266	250	158	139	50	AK-Uni-009	3.8
400	398	13	372	295	198	164	50	AK-Uni-002	6.4
500	498	13	476	345	248	189	48	AK-Uni-010	9.4
600	598	13	567	410	313	222	50	AK-Uni-011	13.2
625	623	13	567	410	313	222	50	AK-Uni-011	13.4

Weights apply to the supply air variant

Diffuser face DLQ

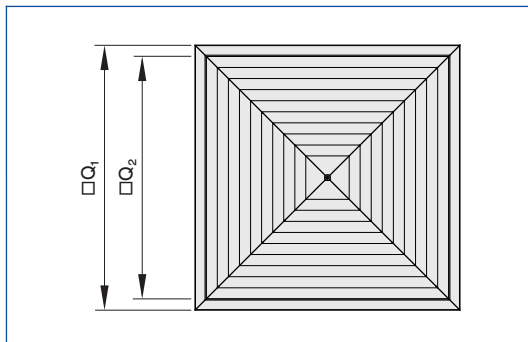

DLQ

Nominal size	$\square Q_1$	$\square Q_2$	A_{eff} m ²
	mm	mm	
250	248	198	0.0095
300	298	248	0.0175
400	398	348	0.0370
500	498	448	0.0675
600	598	548	0.1100
625	623	573	0.1230

Installation in T-bar ceilings, arrangement in a row

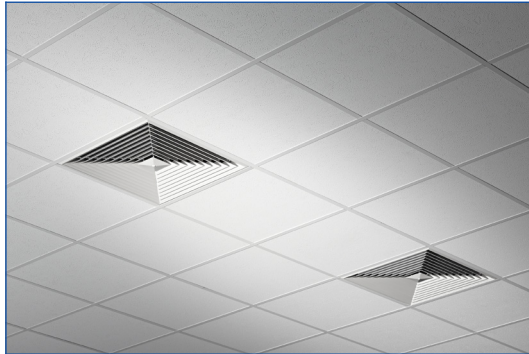

Installation in continuous ceilings

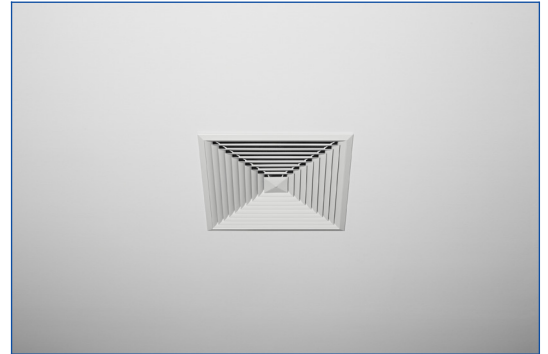

Installation and commissioning

- Preferably for rooms with a clear height up to 4.0 m
- Flush ceiling installation
- Horizontal or vertical duct connection
- If necessary, carry out volume flow rate balancing with the damper blade

These are only schematic diagrams to illustrate installation details.

Flush ceiling installation with square plenum box

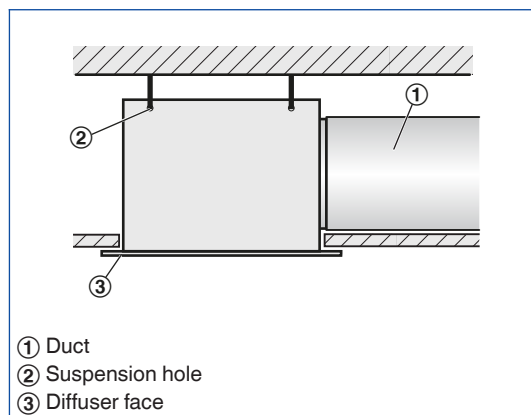

- Horizontal duct connection
- Four suspension holes
- Suspension with cords, wires or hangers, to be provided by others

Diffuser face – sealing

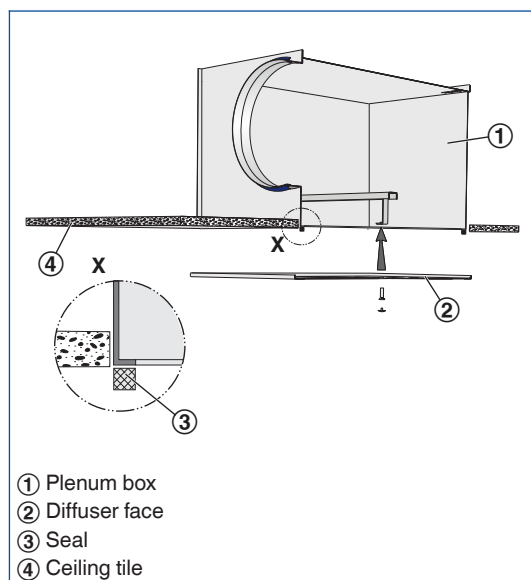

- The self-adhesive sealing tape (supplied) has to be applied to the return edges of the plenum box by others

Diffuser face – central screw fixing

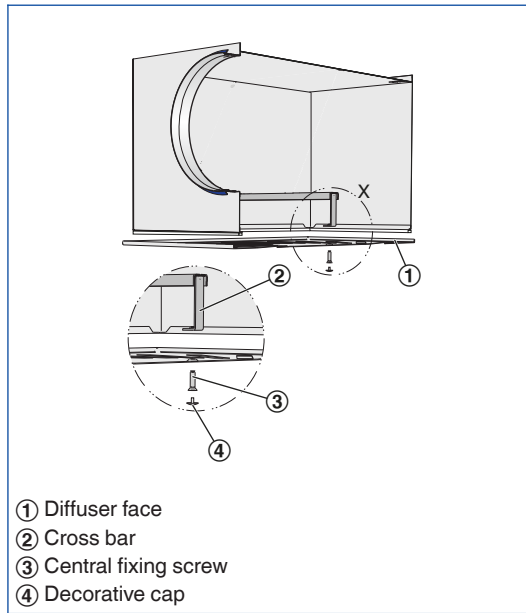

- Using the central fixing screw, fix the diffuser face to the cross bar of the plenum box
- Attach the decorative cap

Ceiling systems

Installation into grid ceilings

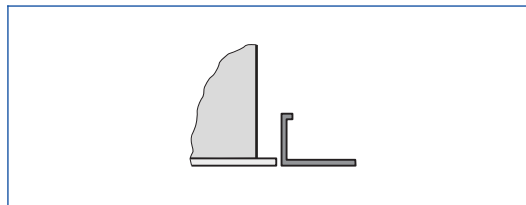

- Fix the plenum box to the ceiling
- The ceiling tile of the grid ceiling is independent of the ceiling diffuser
- Fix the diffuser face after the ceiling has been completed

Installation in continuous ceilings

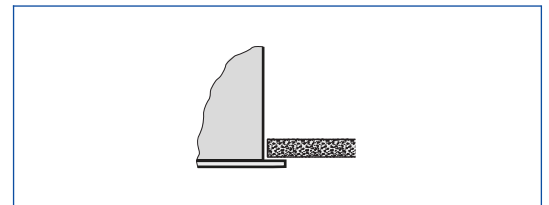

- Fix plenum box (including diffuser face, if necessary) to the ceiling
- Adjust plasterboard ceiling tile as required
- If necessary, fix the diffuser face after the ceiling has been completed

Installation in T-bar ceilings

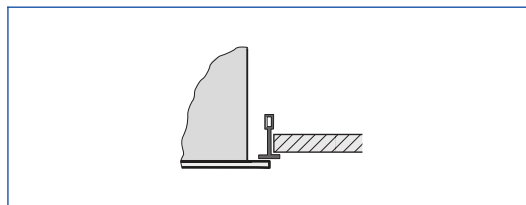

- Fix the plenum box to the ceiling
- The T-bar ceiling is independent of the ceiling diffuser
- Fix the diffuser face below the T-bars after the ceiling has been completed

Volume flow rate balancing

When several diffusers are connected to just one volume flow controller, it may be necessary to balance the volume flow rates.

- Ceiling diffusers with universal plenum box and damper blade (variant -M): The diffuser face can be removed to access the damper blade; the damper blade can then be set to any position between 0 and 90°
- Ceiling diffusers with universal plenum box, damper blade and pressure tap (variant -MN): The diffuser face need not be removed since the damper blade can be set with two cords (white and green).

Volume flow rate measurement

Ceiling diffusers with universal plenum box, damper blade and pressure tap (variant -MN) allow for volume flow rate balancing even with the diffuser face in place.

- Connect the measuring tube to the digital manometer
- Read the effective pressure
- Read the volume flow rate off the characteristic or calculate it
- If necessary, adjust the damper blade position with the cords

A characteristic is included with each AK-Uni plenum box.

AK-Uni-...-MN Volume flow rate balancing

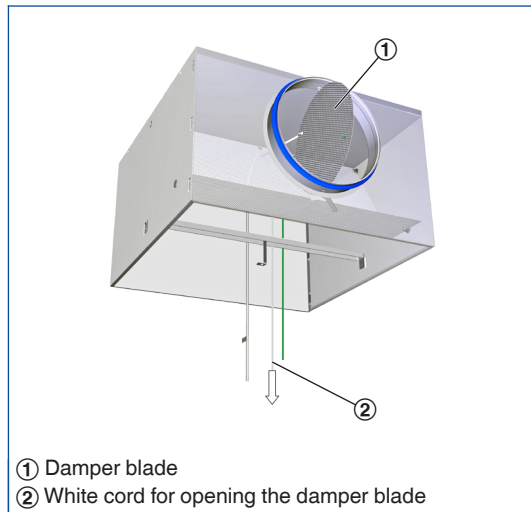

Open, 0°

AK-Uni-...-MN Volume flow rate balancing

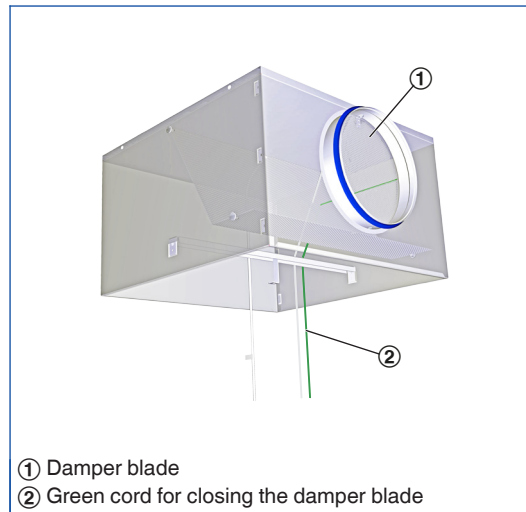

Closed, 90°

AK-Uni-...-MN volume flow rate measurement

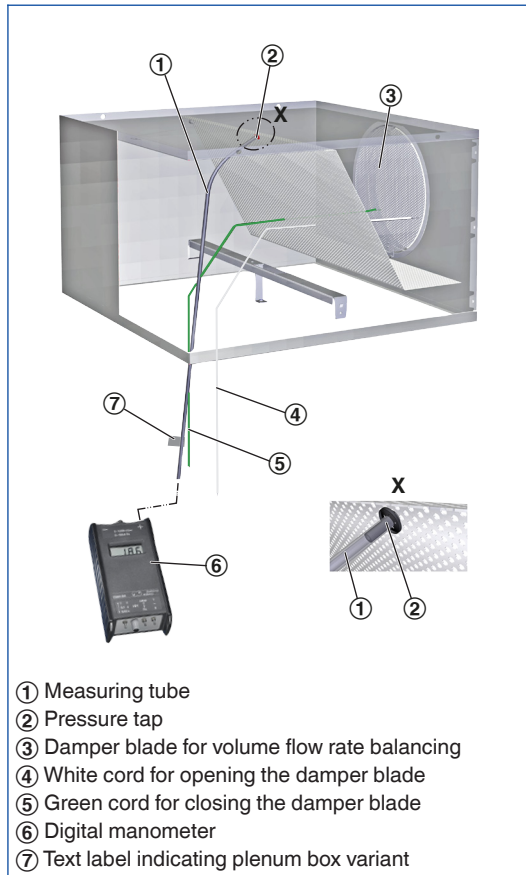

Volume flow rate calculation for air density
1.2 kg/m³

$$\dot{V} = C \times \sqrt{\Delta p_w}$$

Volume flow rate calculation for other air
densities

$$\dot{V} = C \times \sqrt{\Delta p_w} \times \sqrt{\frac{1.2}{\rho}}$$

Principal dimensions

ØD [mm]

Outer diameter of the spigot

ØD₁ [mm]

Outer diameter of a circular diffuser face

ØD₂ [mm]

Diameter of a circular diffuser face style

ØD₃ [mm]

Diameter of a circular plenum box

□Q₁ [mm]

Outer diameter of a square diffuser face

□Q₂ [mm]

Dimensions of a square diffuser face style

□Q₃ [mm]

Dimensions of a square plenum box

H₁ [mm]

Distance (height) from the lower edge of the

suspended ceiling to the lower edge of the diffuser face

H₂ [mm]

Height of a ceiling diffuser, from the lower edge of the suspended ceiling to the upper edge of the spigot

H₃ [mm]

Height of a ceiling diffuser with plenum box, from the lower edge of the suspended ceiling to the upper edge of the plenum box or of the spigot

A [mm]

Position of the spigot, defined by the distance of the spigot centre line to the lower edge of the suspended ceiling

C [mm]

Length of the spigot

m [kg]

Weight

Nomenclature

L_{WA} [dB(A)]

A-weighted sound power level of air-regenerated noise

\dot{V} [m³/h] and [l/s]

Volume flow rate

Δt_z [K]

Supply air to room air temperature difference, i.e.

supply air temperature minus room temperature

Δp_t [Pa]

Total differential pressure

A_{eff} [m²]

Effective air discharge area

All sound power levels are based on 1 pW.